











 Modell	HC382	
Artikelnummer	TT3823GSCDD	
Steuerung : 		

	Äußere Abmessungen (Breite-Tiefe-Höhe) *offen	mm	721 - 836 - 1565(*2080)
	Verpackungsmaße (BxTxH)	mm	870x760x1540
	Bruttogewicht	kg	120
	Nettogewicht	kg	110
	Volumen	m ³	1,02
	Korbgröße	mm	500 x 500
	Maximale Türöffnung	mm	465
	Maximal nutzbare Höhe	mm	450
	Gehäusekonstruktion		doppelwandig
	Tür/Haubenkonstruktion		doppelwandig
	Tankkonstruktion		tiefgezogen
	Tankvolumen	Liter	22
	Tankheizung	W	2500
	Tankflächensieb		edelstahl
	Waschpumpentyp		doppelflutig
	Waschpumpenleistung	W	700
	Waschtemperatur	°C	60 (45-->72)
	Boilertyp		drucklos
	Boilervolumen	Liter	12
	Rückflussverhinderer		Ausgleichsbehälter
	Boilerheizung	W	7000
	Nachspülpumpe		ja
	Nachspülumpenleistung	W	200
	Nachspültemperatur	°C	80 (60-->88)
	Wasserverbrauch der Nachspüllung	Liter /Korb	1,8
	Optimaler externer Wasserdruck	bar	1 - 4
	Ablaufsystem		Tiefenentladung
	Ablauffilter		dreifach filterung
	Ablaufpumpe		Standardmäßig eingebaut
	Klarspülmitteldosierer		ja
	Reinigerdosierer		ja
	Enthärter (Kontinuierlicher Typ)		ohne
	Zyklusdauer	Sekunden	55 - 90 - 180
	Sonder-Zyklen	programme	n° 8
	Selbstreinigungszyklus		ja
	Gesamtanschlußwert	W	10200
	Stromanschluß	V - ph - Hz	400V - 3N - 50Hz
	Absicherung	A	16
	Tellerkorb	N° 1	780131
	Gläserkorb	N° 1	780132
	Besteckköcher	N° 1	780139
	Anschlusskabel		ja
	Ablaufschlauch		ja
	Zulaufschlauch		ja

A		Ø 32 mm
B		G 3/4"
C		Power supply

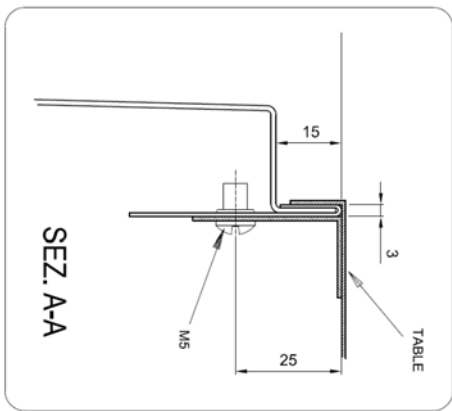
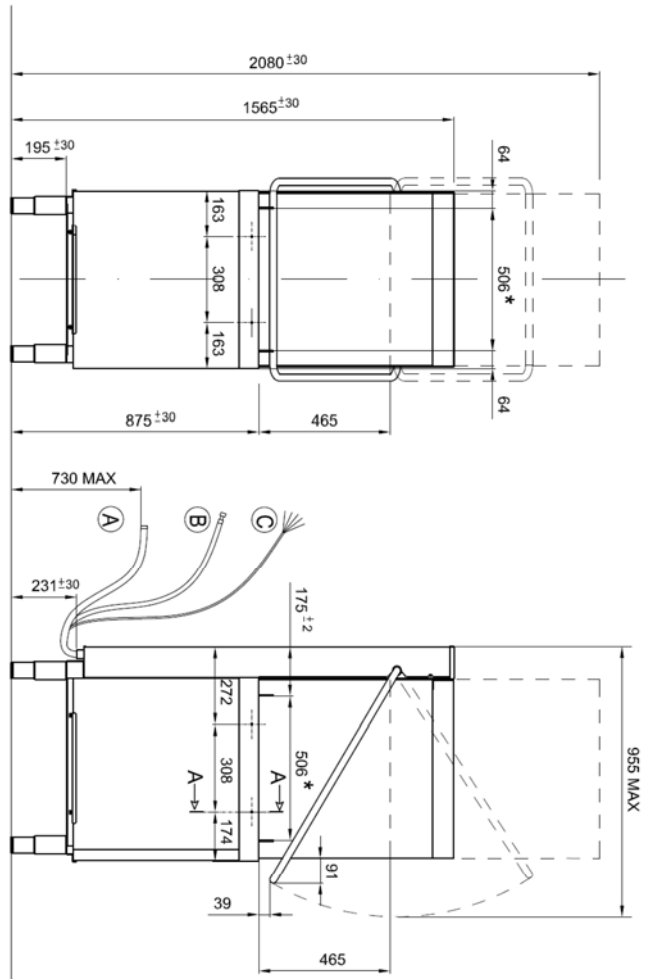
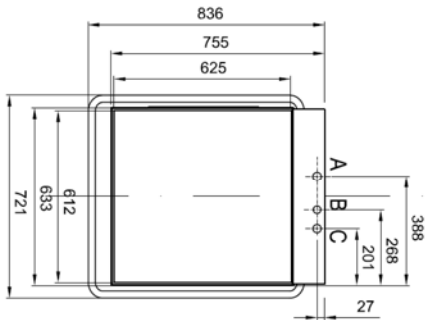

* LUCE UTILE PER GESTELLO
 USEFUL SPACE FOR BASKET
 LUMIERE UTILE POUR PANIER
 NUTZBARE OFFNUNG FÜR KORBE
 ABERTURA UTIL PARA CESTO

Designed by: M.FUCCI Date: 03.12.2013
Installation layout
 Hood type with drain pump
 Code: 73991 Rev.: 01

